

# SHANTUI

## L55-B5

Wheel Loader



Engine Model: Weichai WD10G220E23  
Gross Power: 162kW(220hp)@2000rpm  
Operating Weight: 16,400kg  
Bucket Capacity: 3m<sup>3</sup>

New Appearance  
better performance

# L55-B5 SPECIFICATIONS

## ENGINE

Emission	Tier 2 / Stage II
Model	Weichai WD10G220E23
Rated Power	162 kW (220 hp) @ 2,000 rpm
Max Torque	900 N · m
Displacement	9.726 L
Number of Cylinders	6

## LOADER ARM PERFORMANCE

Tipping Load - Full Turn	11000 kg
Bucket Breakout Force	170 kN
Maximum Dump Angle at Full Height	45°
Dump Clearance at Full Height Discharge	3050 mm
Dump Reach at Full Height Discharge	1110 mm
Maximum Hinge Pin Height	4100 mm
Maximum Digging Depth, Bucket Level	30 mm
Bucket Capacity	3 m <sup>3</sup>
Operating Weight	16400kg

## TRANSMISSION

Transmission Type	Planetary, power shift
Torque Converter	Single stage, four elements
Maximum Travel Speed, fwd	38 km/h
Maximum Travel Speed, rev	15 km/h
Number of Speeds, fwd	2
Number of Speeds, rev	1

## AXLES

Differential Front Type	Conventional
Differential Rear Type	Conventional
Axle Oscillation	±12°

## STEERING

Steering Configuration	Articulated
Steering System Pressure	16 Mpa

## BRAKES

Service Brake Type	Caliper disc brake
Service Brake Actuation	Air over Hydraulic
Parking Brake Type	Flexible shaft control
Parking Brake Actuation	Mechanical

## TIRES

Tire Size	23.5-25-16PR
-----------	--------------

## HYDRAULIC SYSTEM

Main Pump Type	Gear
Main Relief Pressure	18 Mpa
Raise time	5.5 S
Total Cycle Time	10.5 S

## SERVICE CAPACITY

Fuel Tank	300 L
Hydraulic oil Tank	170 L
Engine Oil	21 L
Axles, each	29X2 L
Transmission	45 L
Antifreeze	55 kg

## DIMENSIONS

Length	8220 mm
Width	3066 mm
Height	3450 mm
Wheelbase	3250 mm
Wheel Tread	2238 mm
Ground Clearance	440 mm
Turn Angle, Either Side	35°
Turning Radius, Outside of Tire	6626 mm
Turning Radius, Center of Tire	6326 mm
Turning Radius, Bucket Carry	7200 mm

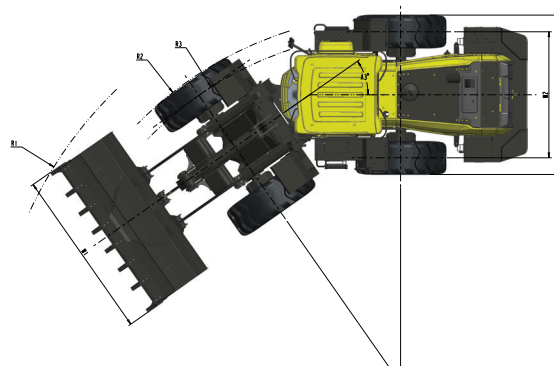
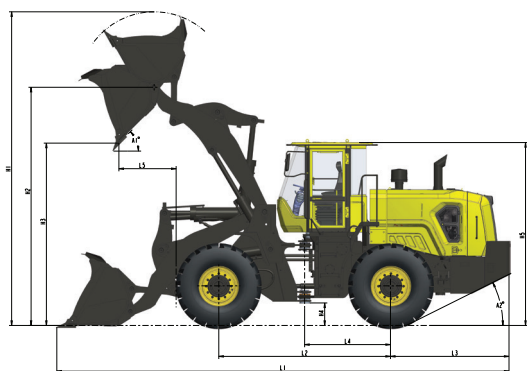

\* THE SPECIFICATIONS ARE SUBJECT TO CHANGE WITHOUT NOTICE. THE PICTURES MAY INCLUDE OPTIONS. THE ACTUAL COLOR & APPEARANCE OF THE PRODUCT MAY DIFFER FROM WHAT IS SHOWN.



Shantui Social

**SHANTUI CONSTRUCTION MACHINERY CO., LTD.**  
 ADD: No. 58, G327 Highway, Jining City, Shandong, CHINA  
 TEL: +86-537-2909369  
 FAX: +86-537-2311219  
 EMAIL: trade@shantui.com  
 WEB: www.shantui.com

**SHANTUI**  
 LET'S MAKE CONSTRUCTION EASIER