

SHANTUI

L36-B3

Wheel Loader



Engine Model: Weichai WP6G125E22
Gross Power: 92kW@2200rpm
Operating Weight: 10,300kg
Bucket Capacity: 1.7m³

Performance and comfort you can feel,
Reliability you can trust!

L36-B3 SPECIFICATIONS

ENGINE

Emission Regulation	Tier 2 / Stage II
Make	Weichai
Model	WP6G125E22
Rated Power	92 kW @ 2,200 rpm
Max Torque	500 N · m
Displacement	6.754 L
Number of Cylinders	6
Aspiration	Turbocharged

LOADER ARM PERFORMANCE

Tipping Load - Full Turn	60 kN
Bucket Breakout Force	95±3 kN
Maximum Dump Angle at Full Height	45°
Dump Clearance at Full Height Discharge	3250 mm
Dump Reach at Full Height Discharge	1000 mm
Maximum Hinge Pin Height	4060 mm
Maximum Digging Depth, Bucket Level	15 mm
Bucket Capacity	1.7 m ³
Operating Weight	10300kg

TRANSMISSION

Transmission Type	Countershaft, power shift
Torque Converter	Single stage, three elements
Maximum Travel Speed, fwd	36 km/h
Maximum Travel Speed, rev	28 km/h
Number of Speeds, fwd	4
Number of Speeds, rev	2

AXLES

Differential Front Type	Conventional
Differential Rear Type	Conventional
Axle Oscillation	±12°

STEERING

Steering Configuration	Articulated
Steering System Pressure	14 Mpa

BRAKES

Service Brake Type	Caliper disc brake
Service Brake Actuation	Air over Hydraulic
Parking Brake Type	Flexible shaft control
Parking Brake Actuation	Mechanical

TIRES

Tire Size	17.5-25
-----------	---------

HYDRAULIC SYSTEM

Main Pump Type	Gear
Main Relief Pressure	21 Mpa
Raise time	5.0 S
Total Cycle Time	9.0 S

SERVICE CAPACITY

Fuel Tank	200 L
Hydraulic oil Tank	165 L
Engine Oil	14 L
Axles, each	36 L
Transmission	36 L
Cooling System	27 kg

DIMENSIONS

Length	7450 mm
Width	2430 mm
Height	3180 mm
Wheelbase	2850 mm
Wheel Tread	1850 mm
Ground Clearance	345 mm
Turn Angle, Either Side	35°
Turning Radius, Outside of Tire	5700 mm
Turning Radius, Center of Tire	5450 mm
Turning Radius, Bucket Carry	6250 mm

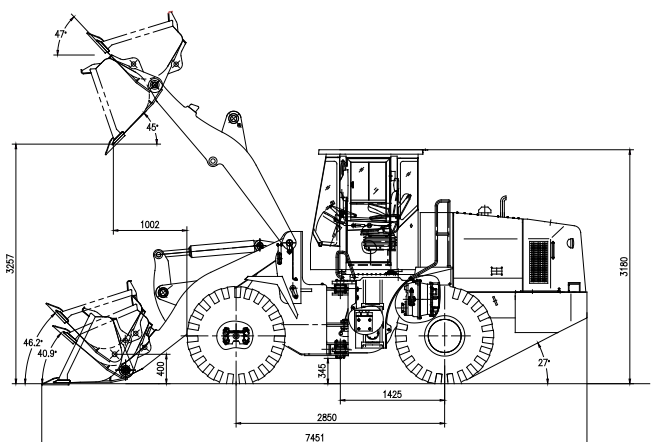
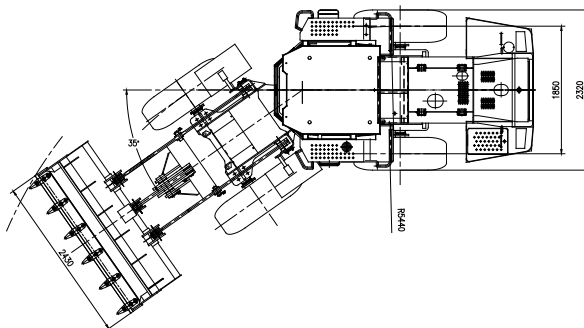

* THE SPECIFICATIONS ARE SUBJECT TO CHANGE WITHOUT NOTICE. THE PICTURES MAY INCLUDE OPTIONS. THE ACTUAL COLOR & APPEARANCE OF THE PRODUCT MAY DIFFER FROM WHAT IS SHOWN.



Shantui Social

SHANTUI CONSTRUCTION MACHINERY CO., LTD.
 ADD: No. 58, G327 Highway, Jining City, Shandong, CHINA
 TEL: +86-537-2909369
 FAX: +86-537-2311219
 EMAIL: trade@shantui.com
 WEB: www.shantui.com

SHANTUI
 LET'S MAKE CONSTRUCTION EASIER